

**IMPORTANT SAFETY INFORMATION. READ AND FOLLOW ALL SAFETY INSTRUCTIONS.** Follow label information and instructions concerning Wet or Damp Locations, installation near combustible materials, insulation, building materials, and proper lamping. Do not install in areas subject to combustible vapors or gases. Before wiring to power supply and during servicing or relamping, turn off power at fuse or circuit breaker. **All servicing or relamping must be performed by qualified service personnel. Product must be grounded to avoid potential electric shock or other potential hazard. Product must be mounted in locations and at heights and in a manner consistent with its intended use, and in compliance with the National Electrical Code and local codes.** The use of accessory equipment not recommended by the manufacturer or installed contrary to instructions may cause an unsafe condition. Do not block light emanating from product in whole or part, as this may cause an unsafe condition. Do not allow items such as drapes, curtains, screens or the like to come into contact with the product or to block light from the product, as this may cause an unsafe condition.

## INSTALLATION INSTRUCTIONS: CFR2 REFLECTOR FOR LFF SQUARE DOWNLIGHTS

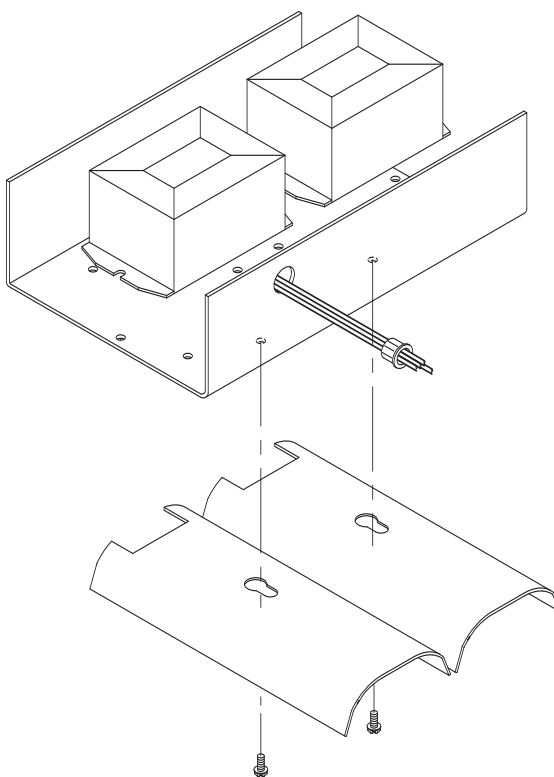

### DUAL LAMP FIXTURES

1. Install the reflectors with the two screws provided in the packet.
2. Drive the screws (2 or 3 turns) into the holes in the bottom of the ballast compartment.
3. Place the reflectors against the ballast compartment and tighten the screws.

### SINGLE LAMP FIXTURES

1. Back the ballast compartment retaining screw out 2 or 3 turns. **DO NOT BACK OUT COMPLETELY!**
2. Place the reflector against the ballast compartment and re-tighten the screw.

