

IMPORTANT SAFETY INFORMATION. READ AND FOLLOW ALL SAFETY INSTRUCTIONS. Follow label information and instructions concerning Wet or Damp Locations, installation near combustible materials, insulation, building materials, and proper lamping. Do not install in areas subject to combustible vapors or gases. Before wiring to power supply and during servicing or relamping, turn off power at fuse or circuit breaker. **All servicing or relamping must be performed by qualified service personnel. Product must be grounded to avoid potential electric shock or other potential hazard. Product must be mounted in locations and at heights and in a manner consistent with its intended use, and in compliance with the National Electrical Code and local building codes.** The use of accessory equipment not recommended by the manufacturer or installed contrary to instructions may cause an unsafe condition. Do not block light emanating from product in whole or part, as this may cause an unsafe condition. Do not allow items such as drapes, curtains, screens or the like to come into contact with the product or to block light from the product, as this may cause an unsafe condition.

INSTALLATION INSTRUCTIONS 4F1 FRAMING PROJECTOR

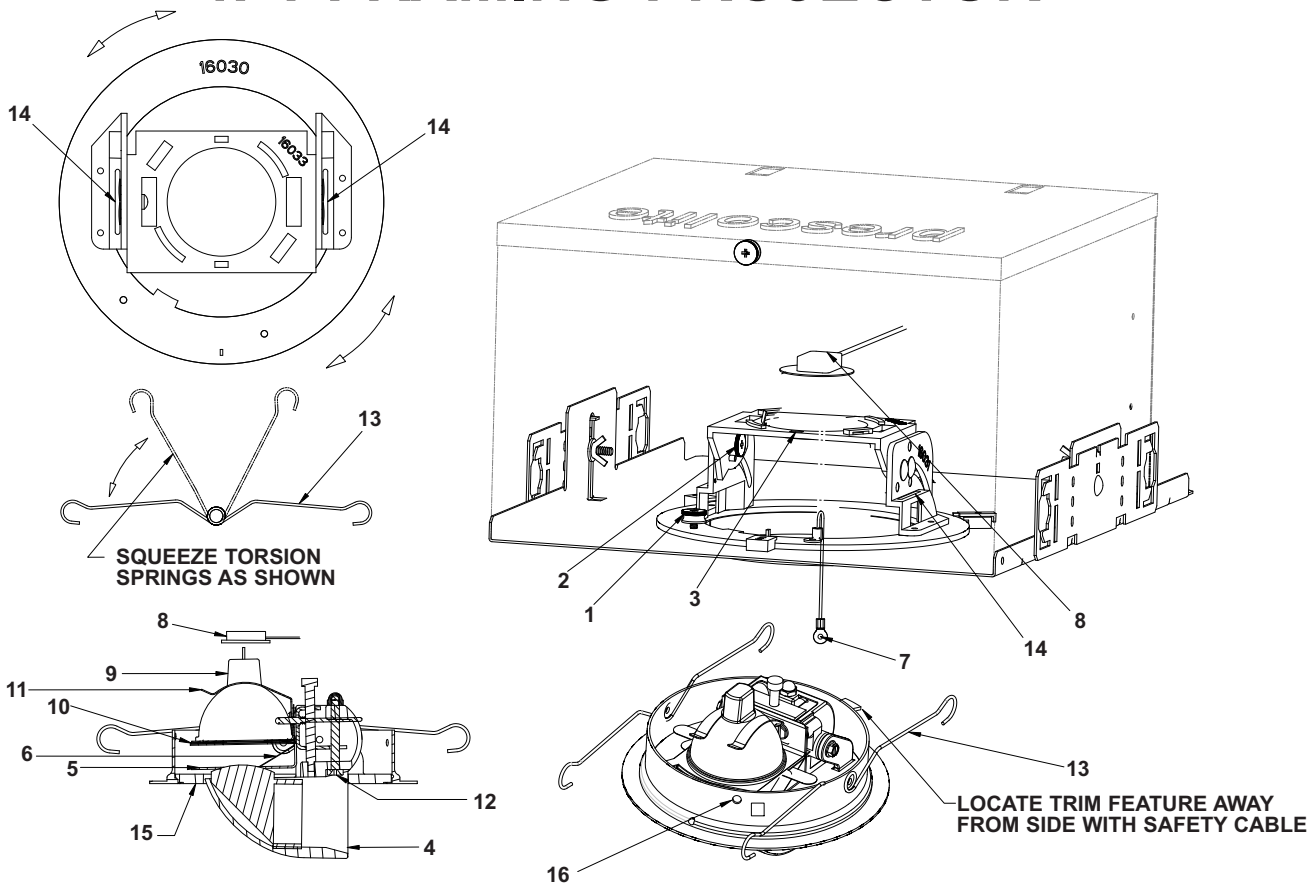

A. PREPARATION (BEFORE INSTALLING TRIM IN CEILING)

1. Loosen horizontal and vertical locking thumbscrews (1) & (2) and rotate lamp mounting plate (3) to 45° degrees vertical. Rotate vertical locking thumbscrew clockwise and lock lamp mounting plate into place in this position.
2. Rotate the scoop (4) horizontally as shown.
3. Familiarize yourself with the Shutter Assembly (5). The functions of the shutter are described below:

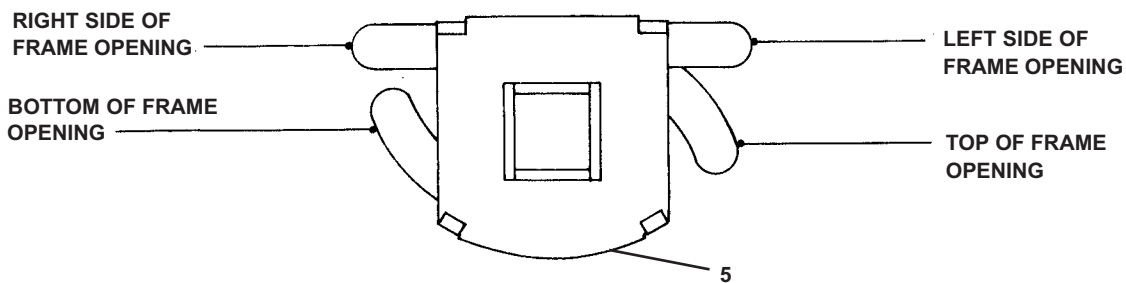

4. Move the shutters and remember, because of the optics in this fixture, the shutter for the right side of the frame is on the left side of the Shutter Ass'y., and the shutter for the left side of the frame is on the right side of the Shutter Ass'y.

CAUTION! Do not completely pull out the shutters from the Shutter Assembly.

5. The Shutter Assembly (5) can be removed from the fixture by pulling up the curved end about 1/8" and then by pulling out the Assembly from below the shutter springs (6).

Removal of the Shutter Assembly (5) is required only to replace the Assembly with a mask or glass slide. See section E. Masking.

B. INSTALLATION INTO HOUSING A4MR OR A4SMR

1. Remove screw (16) and pull the Safety Cable (7) through opening in Plaster Frame and attach to Trim using Screw (16).
2. Pull out the socket (8) from the housing and attach the socket to the Bi-Pin prongs on the lamp (9). Note: If pins are not pushed in all the way, arching will occur, causing premature lamp burnout.
3. Slide lamp (9) between lamp holder (10) and lamp spring (11) as shown.
4. Squeeze the two Torsion Springs (13) together and insert ends into slots on both Brackets (14) as shown.
5. Push Trim towards ceiling until the Torsion Springs force the Trim against the ceiling line.

C. ADJUSTMENT OF TRIM

1. Turn on power.
2. Rotate trim by horizontally by pulling trim slightly away from ceiling.
3. Adjust scoop (4) to the center of the picture.
4. Adjust shutters as described in section A-3. WARNING: Do not touch lamp during trim and shutter adjustment, as high lamp temperatures can cause severe burns. Never attempt to make adjustments after fixture has been under power for longer than 3 min. To make adjustments, always turn off power and let fixture cool down first.
5. Adjust the focus with the phillips head screw (12). If you feel resistance during focus adjustment, change your direction of turning the adjustment screw.

D. FINAL ADJUSTMENT

1. Push up the trim into the housing by holding the scoop (4) with one hand. Readjust the scoop after the face plate (15) is flush with the ceiling.

E. MASKING

1. Instead of the Shutter Assembly, a mask can be used to frame odd-shaped objects.
2. A masking kit is available from Prescolite. Order: MASKING KIT, CAT. NO. LV20.



F. MAXIMUM FRAMING DIMENSIONS

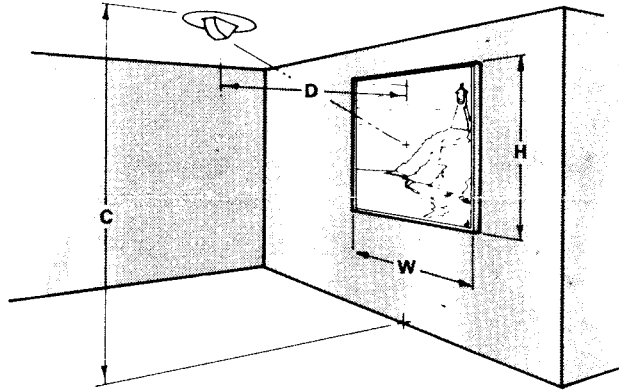

Fixture to Wall Distance (D) Feet	2			4			6			8			10		
Floor to Ceiling Height (C) Feet	8	10	12	8	10	12	8	10	12	8	10	12	8	10	12
Maximum Height of Picture (H) Inches	46			45	81	81	55	76	68	68	84	84	86	95	99
Maximum Width of Picture (W) Inches	17			29	34	34	43	46	46	58	59	59	73	73	74

G. PATTERNS AND SLIDES

Patterns and slides for projection on walls are available from other manufacturers. Contact your Prescolite representative for information.

WARNING: Do not use photographic slides in this framing projector. The high temperature inside the fixture will ruin the slide and also may cause a fire hazard. Only use patterns and logos silkscreened with high temperature paint (180°C, 350°F) on glass.

If sharp focus is desired on all parts of a projected pattern, the pattern itself must be confined within a 0.625" diameter circle. If some lack of focus is acceptable or desirable at the edges (cloud patterns, etc.), then the pattern can be as large as 0.875" diameter.

H. HELPFUL HINTS TO LOCATE THE FIXTURE IN THE CEILING

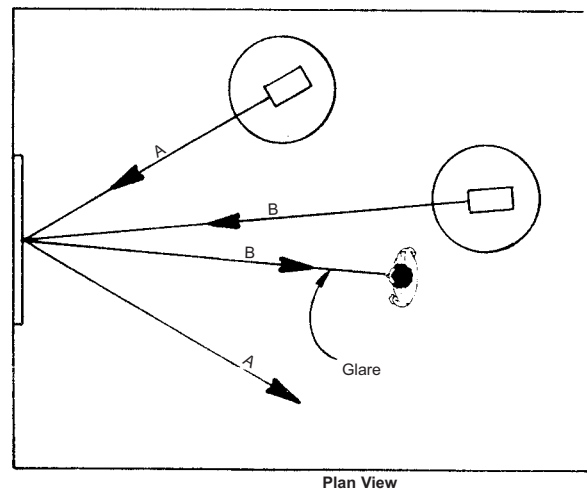
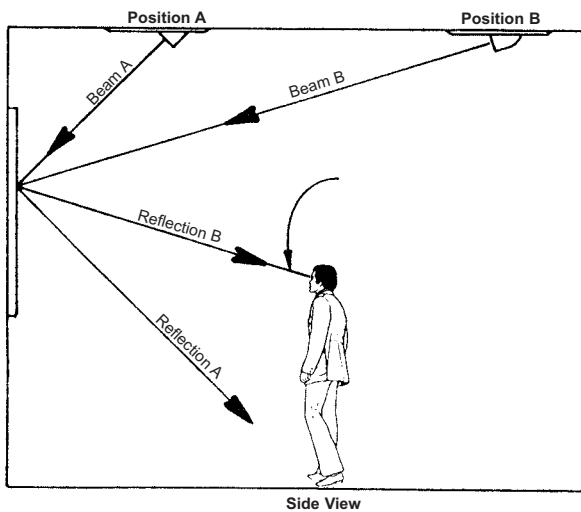

If the Framing Projector is used on a glossy oil painting or picture with a protective glass, an objectionable glare from the picture might be experienced. To reduce or eliminate this glare, consider the following:

The angle of the reflected light from the picture is the same as the angle of the light beam focused onto the picture. The Side View above illustrates how two different Projector positions can affect the glare in the viewer's eye. Naturally, Position A would be preferable.

Sometimes it is not practical to position the Projector as shown in Position A in the Side View. An alternate method to reduce the glare is shown in the Plan View. By mounting the Projector to the side, rather than in front of the picture, the glare can also be reduced or eliminated.

